

ENGINEERED CONCEPTS INC.

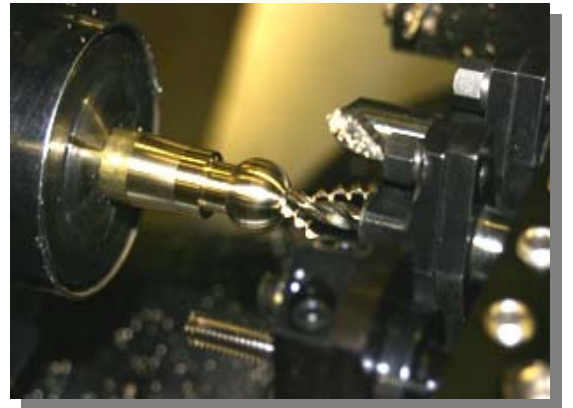

GANG TURN TOOL HOLDER CATALOG

INNOVATIVE, SUPERIOR DESIGN

ENGINEERED CONCEPTS INC

**20 YEARS OF PROVEN, EFFECTIVE, GANG TURN TOOLING DESIGN AND MANUFACTURING.
PRODUCTIVE MACHINING SOLUTIONS**

Each tool has been designed to provide the best use of space without compromising the rigidity or functionality of your machine tool.

The tool holders featured in this catalog can be used alone or with a combination of other holders to best use the space on your tooling plate.

We have provided a number of choices to best suit a wide range of customer requirements, each one tailored to the "gang tool concept".

Our entire range of tool holders are engineered for optimum performance, Features include:

- ◆ Alloy bolts and nickel plated anchoring nuts.
- ◆ 3/8" half dog alloy set screws for secure tool lock down.
- ◆ Thicker tool holders to provide long thread engagement on 3/4" bores
- ◆ The multi position holders, combined with storable and down-loadable tool offsets allows fast change over of jobs.
- ◆ Use the power in your control to store multiple offsets to reduce setup time

ENGINEERED CONCEPTS INC.

1197 FRIES MILL RD.

FRANKLINVILLE NJ 08322

Phone (856) 694-4896 Fax (856) 694-2128

ORDER ON LINE

www.gangturn.com



MULTI-POSITION TOOL STATIONS WHEN FAST CHANGEOVER IS CRITICAL

Differential spacing of the holes in each holder allow different tool configurations for narrow and wide spaced tools on one block.

An end stop mounted to the table provides repeatable location of the tool block for quick changeover of setups.

SINGLE POSITION HOLDERS

- ◆ 3/8" 1/2" & 3/4" center height
- ◆ 5/8" & 3/4" bore size.
- ◆ Left or right handed

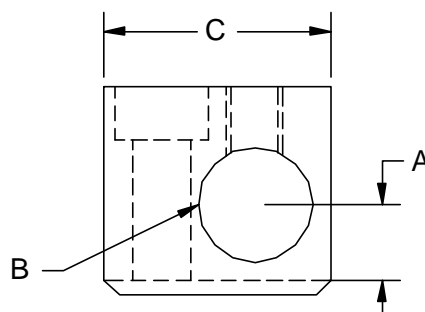

LEFT HAND SHOWN

ADVANTAGES:

Create a custom set up to accommodate any job.

Allows spacing tools of varying lengths, so as not to hit the collet when using a shorter tool.

Smaller width to save space in the X axis.

Part No.	Description	A	B	C	Price
TBS-1356	3/8" center height 5/8" bore Right hand	.3750	.6250	1.500	\$80.00
TBS-1357	3/8" center height 5/8" bore Left hand	.3750	.6250	1.500	\$80.00
TBS-1456	1/2" center height 5/8" bore Right hand	.5000	.6250	1.500	\$80.00
TBS-1457	1/2" center height 5/8" bore Left hand	.5000	.6250	1.500	\$80.00
TBS-1466	1/2" center height 3/4" bore Right hand	.5000	.7500	1.500	\$80.00
TBS-1467	1/2" center height 3/4" bore Left hand	.5000	.7500	1.500	\$80.00
TBS-1426	1/2" center height 20mm bore Right hand	.5000	20 mm	1.500	\$90.00
TBS-1427	1/2" center height 20mm bore Left hand	.5000	20 mm	1.500	\$90.00
TBS-1666	3/4" center height 3/4" bore Right hand	.7500	.7500	1.500	\$90.00
TBS-1667	3/4" center height 3/4" bore Left hand	.7500	.7500	1.500	\$90.00
TBS-1626	3/4" center height 20mm bore Right hand	.7500	20 mm	1.500	\$90.00
TBS-1627	3/4" center height 20mm bore Left hand	.7500	20 mm	1.500	\$90.00

SINGLE POSITION HEAVY DUTY

- ◆ Double bolt down for heavy cutting
- ◆ 3/8", 1/2" & 3/4" center height
- ◆ 5/8", 3/4" & 1.0" bore size.

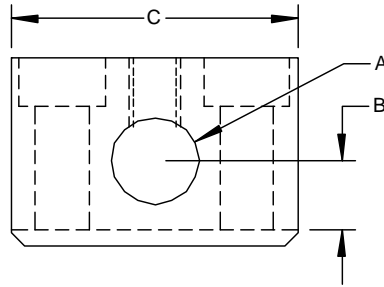

ADVANTAGES:

These holders are designed for heavier cuts.
Double hold down bolts provide extra clamping for heavy turning and boring.

Part No.	Description	A	B	C	Price
TBS-1350	3/8" center height 5/8" bore	.6250	.3750	2.100	\$90.00
TBS-1450	1/2" center height 5/8" bore	.6250	.5000	2.100	\$90.00
TBS-1460	1/2" center height 3/4" bore	.7500	.5000	2.100	\$90.00
TBS-1420	1/2" center height 20 mm bore	20 mm	.5000	2.100	\$100.00
TBS-1660	3/4" center height 3/4" bore	.7500	.7500	2.100	\$100.00
TBS-1680	3/4" center height 1.0" bore	1.0000	.7500	2.350	\$100.00
TBS-1620	3/4" center height 20 mm bore	20 mm	.7500	2.100	\$100.00

2 POSITION HOLDERS

- ◆ 3/8", 1/2" & 3/4" center height.
- ◆ 5/8", 3/4" & 1.0" bore size.

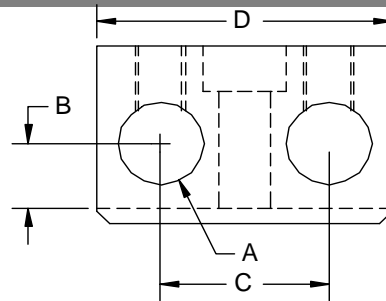

ADVANTAGES:

Slightly wider than the one position with a compact area for two operations.
Gives ability to ID bore and OD turn without reversing spindle.
Use a split point drill first then bore 2nd without need of a center drill.

Part No.	Description	A	B	C	D	Price
TBS-2354	3/8" center height 5/8" bore	.6250	.3750	1.250	2.200	\$95.00
TBS-2454	1/2" center height 5/8" bore	.6250	.5000	1.250	2.200	\$95.00
TBS-2464	1/2" center height 3/4" bore	.7500	.5000	1.250	2.200	\$95.00
TBS-2420	1/2" center height 20 mm bore	20 mm	.5000	1.250	2.200	\$105.00
TBS-2664	3/4" center height 3/4" bore	.7500	.7500	1.250	2.200	\$105.00
TBS-2684	3/4" center height 1.0" bore	1.0000	.7500	1.500	2.750	\$ 125.00
TBS-2620	3/4" center height 20 mm bore	20 mm	.7500	1.250	2.200	\$105.00

3 POSITION HOLDERS

- ◆ 3/8", 1/2" & 3/4" center height.
- ◆ 5/8", 3/4" & 1.0" bore size

ADVANTAGES:

This tool is ideal for spot, drill & tap operation.
Combined drilling, turning or boring work.
Two hold down bolts for enhanced rigidity.



Part No.	Description	A	B	C	D	E	Price
TBS-3354	3/8" center height 5/8" bore	.6250	.5000	1.250	3.500	1.250	\$105.00
TBS-3454	1/2" center height 5/8" bore	.6250	.5000	1.250	3.500	1.250	\$105.00
TBS-3464	1/2" center height 3/4" bore	.7500	.5000	1.250	3.500	1.250	\$105.00
TBS-3420	1/2" center height 20 mm bore	20 mm	.5000	1.250	3.500	1.250	\$135.00
TBS-3664	3/4" center height 3/4" bore	.7500	.7500	1.250	3.500	1.250	\$135.00
TBS-3684	3/4" center height 1.0" bore	1.000	.7500	1.500	4.200	1.500	\$155.00
TBS-3620	3/4" center height 20 mm bore	.7500	.7500	1.250	3.500	1.250	\$135.00

4 POSITION HOLDERS

- ◆ 3/8", 1/2" & 3/4" center
- ◆ 5/8" & 3/4" bore size
- ◆ 1.25" spacing

ADVANTAGES:

Extended version of the 3 position.
Set one tool in the X axis, and just add
1.250" in the control for each of the others.
A versatile mid size holder.
Available in 5/8" or 3/4" bore.

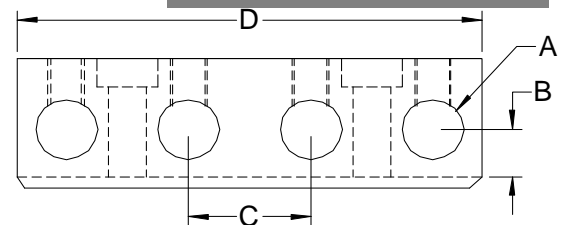

Part No.	Description	A	B	C	D	Price
TBS-4354	3/8" center height 5/8" bore	.6250	.3750	1.250	4.750	\$155.00
TBS-4454	1/2" center height 5/8" bore	.6250	.5000	1.250	4.750	\$155.00
TBS-4464	1/2" center height 3/4" bore	.7500	.5000	1.250	4.750	\$155.00
TBS-4420	1/2" center height 20 mm bore	20 mm	.5000	1.250	4.750	\$165.00
TBS-4664	3/4" center height 3/4" bore	.7500	.7500	1.250	4.750	\$165.00
TBS-4620	3/4" center height 20 mm bore	20 mm	.7500	1.250	4.750	\$175.00

6 POSITION HOLDERS

ADVANTAGES:

The 6 position holder provides a section of 3 bores on .875 centers, which saves space on the X axis, while providing a good spot, drill and tap area.

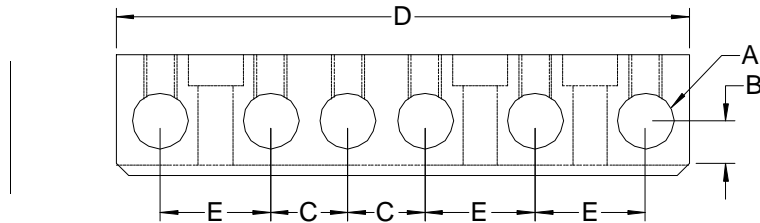

Part No.	Description	A	B	C	D	E	Price
TBS-6350	3/8" center height 5/8" bore	.6250	.3750	.875	6.500	1.250	\$240.00
TBS-6450	1/2" center height 5/8" bore	.6250	.5000	.875	6.500	1.250	\$240.00
TBS-6460	1/2" center height 3/4" bore	.7500	.5000	.875	6.500	1.250	\$240.00
TBS-6420	1/2" center height 20mm bore	20 mm	.5000	.875	6.500	1.250	\$295.00
TBS-6660	3/4" center height 3/4" bore	.7500	.7500	.875	6.500	1.250	\$295.00
TBS-6620	3/4" center height 20 mm bore	20 mm	.7500	.875	6.500	1.250	\$295.00

8 POSITION HOLDERS

ADVANTAGES:

This holder is perfect for a **repeat** production runs, after the first set up and production run, save the tool offsets in your program. Remove the holder with all tooling clamped in place. On the next production run simply reinstall and load your program.

Overall length of 9" allows flexibility on big setups.

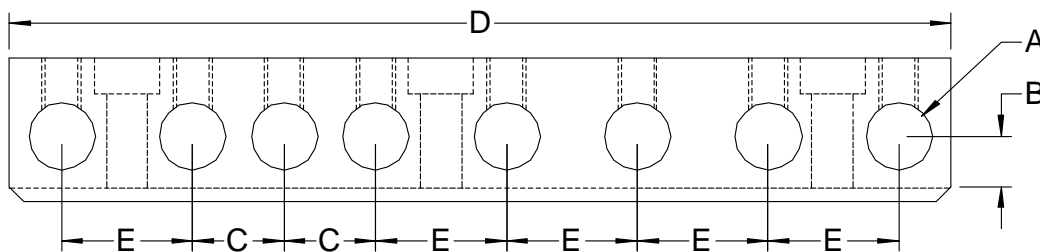

Part No.	Description	A	B	C	D	E	Price
TBS-8350	3/8" center height 5/8" bore	.6250	.3750	.875	9.000	1.250	\$295.00
TBS-8450	1/2" center height 5/8" bore	.6250	.5000	.875	9.000	1.250	\$295.00
TBS-8460	1/2" center height 3/4" bore	.7500	.5000	.875	9.000	1.250	\$295.00
TBS-8420	1/2" center height 22 mm bore	20 mm	.5000	.875	9.000	1.250	\$295.00

MACHINABLE TOOL STATION

The perfect solution to the custom job. 4.250' of space for any special bore centers or diameters to suit your application. Machinable steel, black oxide finish, complete with hold down hardware.

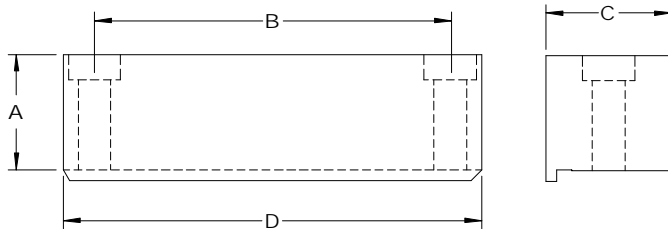

Part No.	Description	A	B	C	D	Price
TBS-0600	Machinable Station	1.500	4.250	1.625	5.00	\$60.00

TURNING AND FACING HOLDERS

CONVENIENT SPACE SAVING DESIGN

- ◆ Turn and face with the same tool.
- ◆ Accepts 0.500" or 0.750" shank square tools
- ◆ Cut down on unnecessary additional tools .
- ◆ Offered in right or left hand to accommodate any application.
- ◆ Solid positive lock down directly to the table for deeper cuts.
- ◆ Eliminates chatter and harmonics.
- ◆ Recommended inserts: 80 deg diamond , triangle or trigon

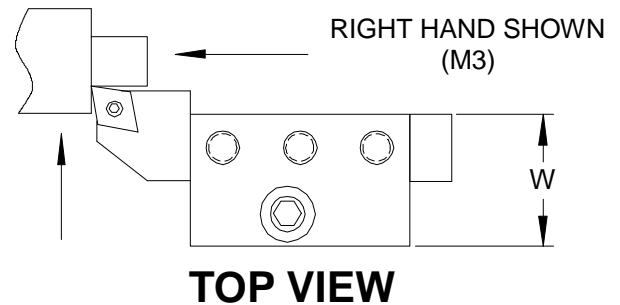

TOP VIEW

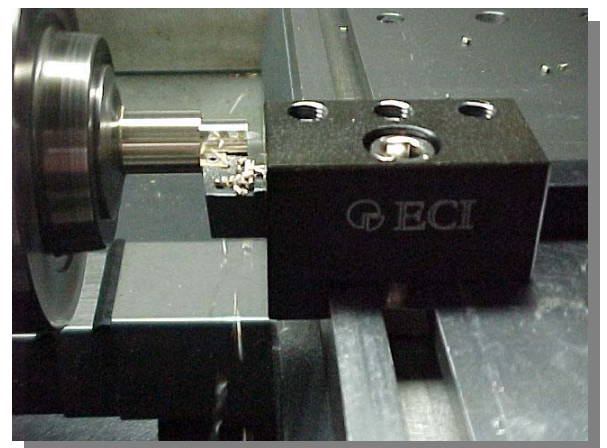
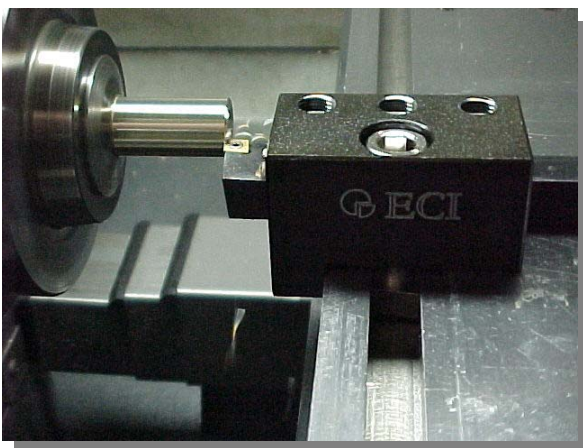

Part No.	Description	W	Price
TBA-1446	1/2" center 1/2" Square tool RH	1.250	\$80.00
TBA-1447	1/2" center 1/2" Square tool LH	1.250	\$80.00
TBA-1666	3/4" center 3/4" Square tool RH	1.250	\$90.00
TBA-1667	3/4" center 3/4" Square tool LH	1.250	\$90.00

Posi-Lock™ System Operation

The Posi-Lock™ system provides an easy to use, accurate tool alignment system.

These instructions explain the operation of each component.

System Breakdown

1. Posi-Lock Post.
2. Posi-Lock Head.
3. Clamp Wedge.
4. Adjusting Screw.
5. Hold Down Screws.
6. Locking Screws.
7. Tool Clamp Screws.
8. T Nuts.
9. Dowel Pin.

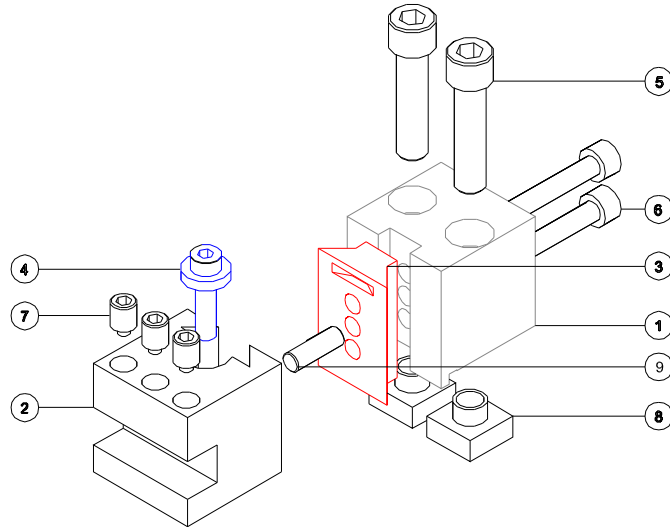

Initial Assembly

Each post (1) arrives with a wedge clamp (3) and locking screws (6) attached. A dowel pin (9) aligns the wedge to stop vertical movement. The hold down screws (5) are attached to the T nuts (8).

The heads (2) have the adjusting screw (4) assembled, along with the tool clamp screws.

To setup a post to a head, remove the adjusting screw from the head and loosen the locking screws on the post.

Slide the head onto the clamp wedge, and replace the adjusting screw so that the flange of the adjusting screw is interlocked into the clamp wedge.

This allows the adjusting screw to lift or lower the head. For odd size tools or special center heights the adjusting screw can sit on top of the wedge.

To fine adjust a center height, follow these steps.

1. Loosen the top locking screw and lightly snug back down (just enough to support the weight of the head.)
2. Loosen the 2nd screw (usually the lower screw.)
3. Adjust the tool up or down with the adjusting screw.
4. Lock the 2 locking screws in place.

If the locking screws are both loosened together, the head will move easily causing erratic adjustment.

If the screws are not loosened enough it is possible to bend the wedge lip or the adjusting screw.

If you are setting live tools or require exact positioning of the tool, a dial indicator on a mag-base can be used to check the amount of movement.

Posi-Lock™ System Operation

Assembled View

This view shows a post and a 1.5" extension head assembled.

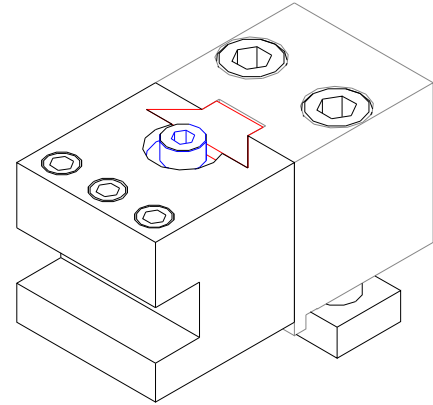

Center Height Choices

On a standard 1.5" post, the ranges of center heights are shown below.

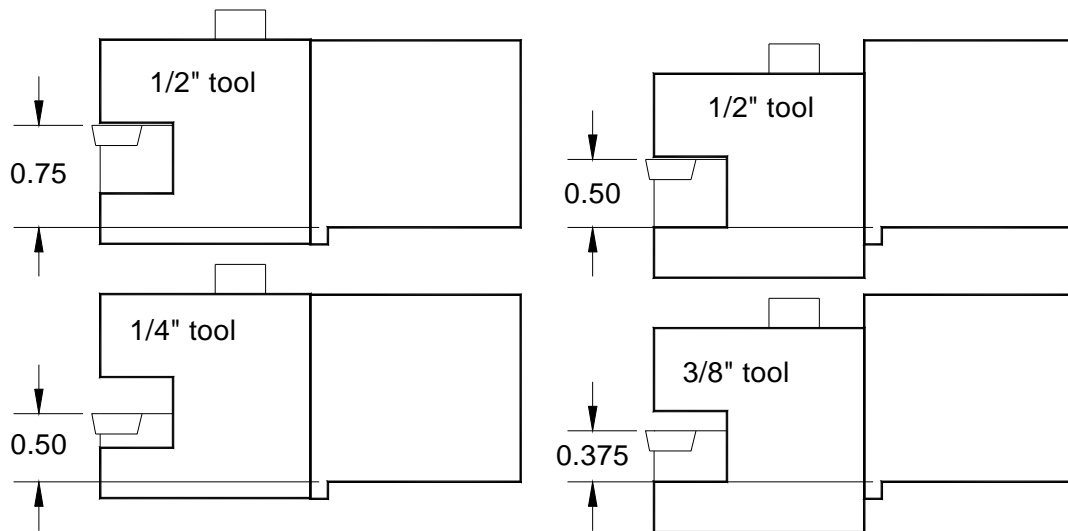

It is possible to open up the tool slot to 5/8" (16mm) for slightly larger tools.

Always remove metal from the top of the slot.

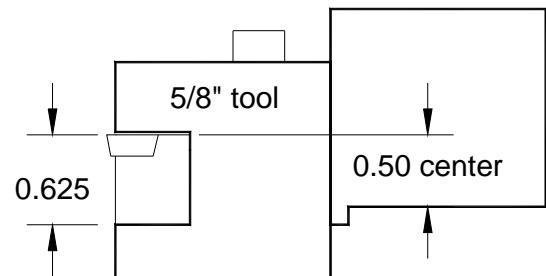

Setting Tools Upside Down

The tool blocks have been designed to allow the base of the slot to be raised to 1/2" center.

This allows any size tool up to 5/8" shank to be mounted upside down to optimize spindle rotation for special needs.

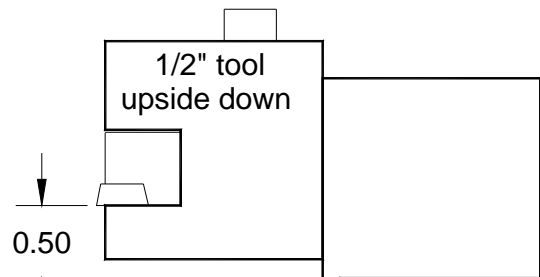

We do not recommend the use of negative rake insert tools of 3/4" center height in these holders.

The head extension can cause undue loading.

When using negative rake holders, we recommend the axial tool holders that have a fixed center height.



PPS-0150

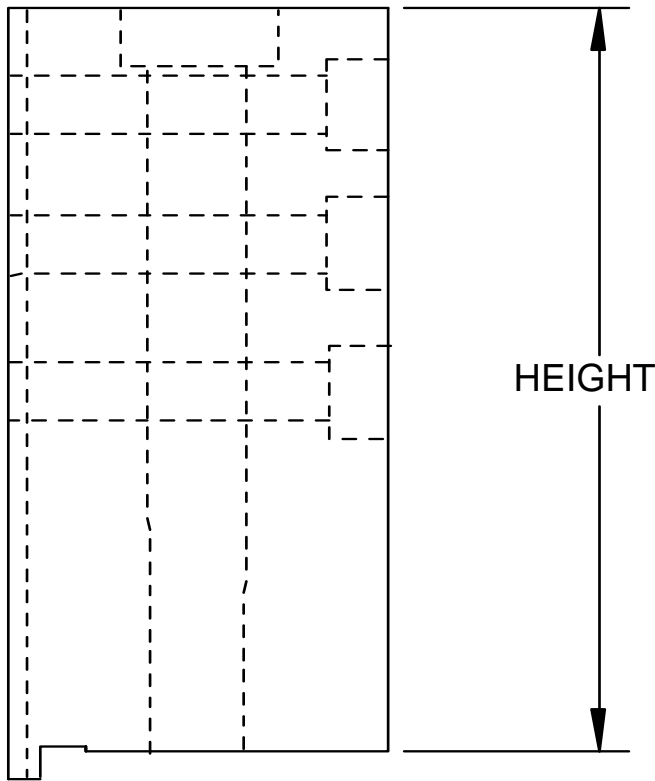

- PPS-0150 = 1.375 1/2" CTR TOOLING**
- PPS-0175 = 1.625 3/4" CTR TOOLING**
- PPS-0350 = 3.500 LIVE TOOLING**
- PPS-0400 = 4.000 LIVE TOOLING**
- PPS-0500 = 5.500 LIVE TOOLING**

Part No.	Description	Price
PPS-0150	Posi-Lock Post for 1/2" center.	\$95.00
PPS-0175	Posi-Lock Post for 3/4" center.	\$105.00
PPS-0350	Posi-Lock Post 3.500 height live	\$150.00
PPS-0400	Posi-Lock Post for 4.000 height live	\$160.00
PPS-0500	Posi-Lock Post for 5.500 height live	\$195.00

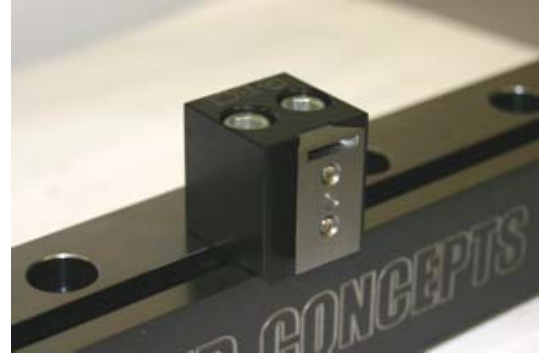

PPS-0175

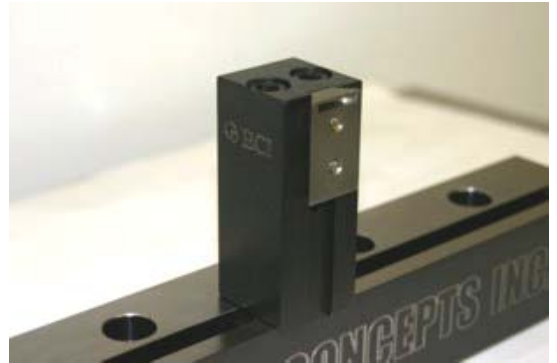

PPS-0350

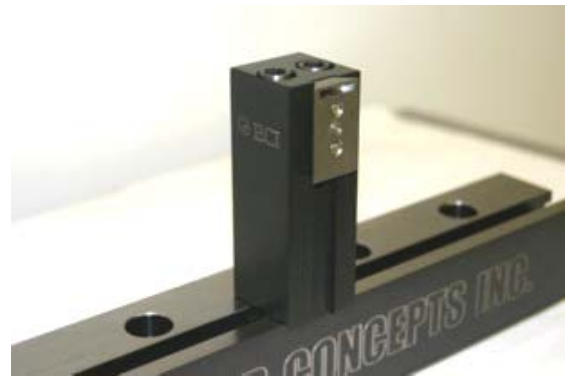

PPS-0400



PPS-0500

POSI-LOCK DOVETAIL SYSTEMS MOUNT UNIVERSAL POSTS & JUST CHANGE THE HEADS

When it comes to locking the tool block to the post we don't mess around with weak set screws or "cam type" wedges.

The dovetail plate is drawn back to the post with two cap head **bolts** from the rear. Creating a solid, vibration free, won't loosen up, work horse of a holder. To adjust center simply loosen the rear bolts, insert a hex key in the jack screw, center the tool, and lock it back in place.

EXTENSION HEADS

TURNING OR CUT-OFF TOOLS

- ◆ Compact....Post is only 1.50" wide.
- ◆ Double cap head bolts for solid lock down to the table.
- ◆ Vibration free double bolted dovetail.
- ◆ Can be used on either side of the work piece.
- ◆ Fine adjustment leveling screw for precise centering.
- ◆ Holds square tools up to 0.5"



>>Post and heads are sold as separate items. <<

Part No.	Description	A	Price
PPS-0150	Posi-Lock Post for 1/2" center.		\$95.00
PPS-0175	Posi-Lock Post for 3/4" center.		\$105.00
PEX-2000	Machinable Blank, Posi-Lock Head,	1.000	\$75.00
PEX-2100	1" Extension Turning Tool Holder	1.000	\$95.00
PEX-2200	2" Extension Turning Tool Holder	2.000	\$115.00
PEX-2300	3" Extension Turning Tool Holder	3.000	\$125.00

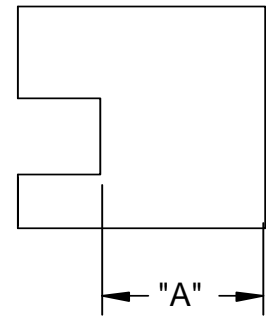

COMBO TURN HEADS

IDEAL FOR FACING & TURNING

- ◆ Accepts up to 0.50" square tools
- ◆ Used in turning and / or facing.
- ◆ Offered in right or left hand to accommodate any application.
- ◆ Fine adjustment leveling screw for precise centering.
- ◆ Easy change over for modular tooling.
- ◆ Could be used to hold 2 tools.
- ◆ Shown with post, sold separately



Part No.	Description	Price
PPS-0150	Posi-Lock Post for 1/2" center.	\$95.00
PPS-0175	Posi-Lock Post for 3/4" center.	\$105.00
PST-2106	Right Hand Combo Turning Holder	\$115.00
PST-2107	Left Hand Combo Turning Holder	\$115.00

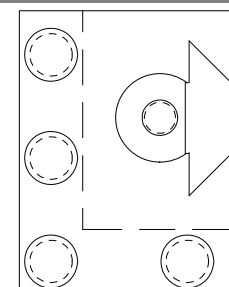

Left hand shown

T BLADE CUT-OFF HEAD

USE WITH HSS OR CARBIDE TIPPED "T" BLADES

- ◆ Accepts 0.04" to 0.125" wide blades. 5/8" to 11/16" high
- ◆ Position on far side of the table to conserve space.
- ◆ Right or left hand approach.
- ◆ Sturdy design insures straight cuts.
- ◆ Fine adjustment leveling screw for precise centering.
- ◆ Easy change over modular tooling.
- ◆ Shown with post.

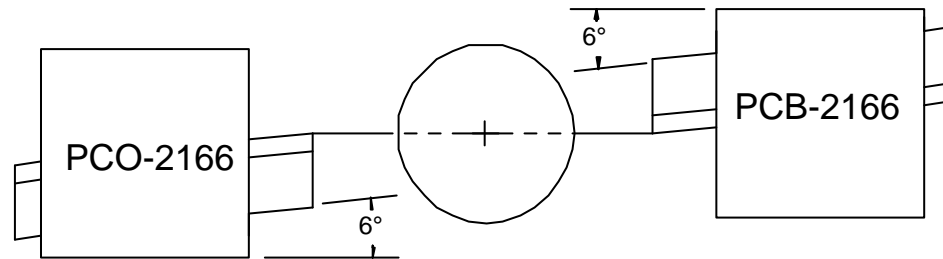

Part No.	Description	Price
PCO-2160	11/16" Blade, 0 Deg Rake Cut-off Holder	\$95.00
PCO-2166	11/16" Blade, 6 Deg Rake Cut-off holder	\$95.00
PCB-2166	11/16" Blade, 6 Deg Rake Rear Cut-off holder	\$95.00

THREE POSITION DRILL HEAD IDEAL FOR SMALL WORK WHEN TABLE ROOM IS TIGHT

Enables use of three drills or other tools only taking 2" of space.

Uses 1/2" standard ECI split bushings.

Fine adjustment leveling screw for precise centering.



Part No.	Description	Price
PPS-0150	Posi-Lock Post for 1/2" center.	\$95.00
PPS-0175	Posi-Lock Post for 3/4" center.	\$105.00
PDA-3040	Compact 3 Position Tool Holder	\$90.00

LIVE SPINDLE HOLDERS

LIVE TOOL WORK IS NOW EASIER THAN EVER

Assorted Live Tool Mounts offering these features :

Accepts 22.8 mm, 25 mm , 30 mm, 36 mm or 1.0" diameter **NSK** or **Finley** live tooling spindles.

Heads are only 2" wide.

Available in both right and left hand orientation

2 secure front clamping bolts.

Adjustment leveling screw for precise centering.

Vibration free double bolted dovetail design.

RADIAL LIVE HOLDERS

CROSS DRILL OR MILLING

- ◆ Used in cross drilling or slot milling.
- ◆ Also used with C axis for contour milling.
- ◆ Milling and engraving capability with C axis.
- ◆ Leveling screw for precise height adjustment.
- ◆ Adapter bushings available
- ◆ Live tool or post not included.

Recommended configuration:

1.00" 22.8, 25 mm spindles: PPS-0150 & PLR-51XX

30 & 36 mm spindles : PPS-0175 & PLR-53XX



NSK 22.8 mm Spindle



Finley 36 mm Spindle

Part No.	Description	Price
PPS-0150	Posi-Lock Post for 1/2" center.	\$95.00
PPS-0175	Posi-Lock Post for 3/4" center.	\$105.00
PLR-5100	22.8 mm Radial Live Tool Holder	\$135.00
PLR-5125	25 mm Radial Live Tool Holder	\$135.00
PLR-5110	1.00" Radial Live Tool Holder	\$135.00
PLR-5306	30 mm Radial Live Tool Holder	\$155.00
PLR-5360	36 mm Radial Live tool Holder	\$195.00

TWO POSITION RADIAL LIVE HOLDERS

FOR 22.8 MM NSK

- ◆ Two in the space of one.
- ◆ More flexibility when using different drill sizes in one operation.
- ◆ Milling and engraving capability with C axis.
- ◆ Micrometer leveling screw for precise height adjustment.
- ◆ Live tool or post not included.



Part No.	Description	Price
PPS-0150	Posi-Lock Post for 1/2" center.	\$95.00
PPS-0175	Posi-Lock Post for 3/4" center.	\$105.00
PLR-5200	22.8 2 Pos. Radial Live Tool Holder	\$155.00

AXIAL LIVE HOLDERS

Precise centering for high speed small diameter drilling or milling.

The perfect tool for off center holes.

Add a 90° head for cross drilling applications.

Universal indicates head can be mounted right or left of post.

Live tool or post not included.

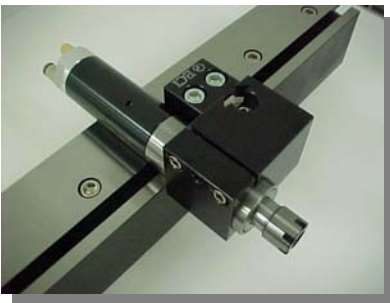

Finley 36 mm Spindle



NSK 22.8 mm Spindle

Part No.	Description	Price
PPS-0150	Posi-Lock Post for 1/2" center.	\$95.00
PPS-0175	Posi-Lock Post for 3/4" center.	\$105.00
PLA-5206	Universal Hand 22.8 mm Axial Live Tool Holder / use with PPS-0150	\$135.00
PLA-5306	Universal Hand 30 mm Axial Live Tool Holder / use with PPS-0175	\$155.00
PLA-5366	Universal Hand 36 mm Axial Live Tool Holder / use with PPS-0175	\$165.00

VERTICAL LIVE HOLDERS

SLOT ,SAW OR SHAPE MILL

- ◆ The perfect tool for sawing, slotting, and shape milling.
- ◆ Choose a 3.5" 4" or 5.5" high post
- ◆ Adapter bushings available
- ◆ Universal indicates head can be mounted left or right of post.
Live tool or post not included.

For machines with more than 1" capacity, a PPS-0500 is required for vertical (overhead) operations.



NSK 22.8 mm Spindle



Finley 36 mm Spindle

Part No.	Description	Price
PPS-0350	3.5" Overhead Dovetail Post	\$150.00
PPS-0400	4.0" Overhead Dovetail Post	\$160.00
PPS-0500	5.0" Overhead Dovetail Post	\$195.00
PLV-5206	Universal 22.8 mm Overhead Live Tool Holder	\$150.00
PLV-5306	Universal 30 mm Overhead Live Tool Holder	\$155.00
PLV-2300	Neutral 23 mm extended 2" from post	\$150.00
PLV-5366	Universal 36 mm Overhead Live Tool Holder	\$195.00

FIXED CENTER AXIAL LIVE HOLDER

- ◆ Designed for light duty precise machining.
- ◆ Double bolt down for vibration free operation.
- ◆ Two locking set screws arranged in parallel.

Delrin locking elements.

For 22.8, 25 mm & 1.0" **NSK** Live spindle.

Fixed 1/2" center height only

Live air tool not included.



Part No.	Description	Price
TLA-1230	22.8 mm Axial, 1/2" Center, live tool holder	\$175.00
TLA-1250	25 mm Axial, 1/2" Center, live tool holder	\$175.00
TLA-1254	1.0" Axial, 1/2" Center, live tool holder	\$175.00
TLA-1630	30 mm Axial, 3/4 Center, live tool holder	\$175.00

LIVE TOOL SYSTEMS FOR DAEWOO, KIA, & HYUNDAI

This system will bolt to any 85 mm center height machine listed. Ideal for the user that wishes to continue using the original larger tooling that was provided by the manufacturer. Shown here is an axial configuration. Radial and vertical versions are listed below. Precise centering is achieved by loosening the lock bolts behind the post, then turning the fine adjustment jack screw. The spindle is held by two cap screws that securely clamp it in a forward or shortened extension. Ideal for centering small drills, face milling, or off center applications. Key tab in the base fits into the tee slot of the main table. Tee nuts and alloy bolts provide a secure anchoring.

For cross drilling, radial, operations, a PLR-5360 would be mounted, adjustment is as before.

Slotting, milling flats and hexes, a vertical, PLV-5366 is the choice.

Each unit listed below comes with one choice of positions. Other heads are available as needs arise.

UNITS COME COMPLETE WITH ALL NECESSARY HARDWARE



Reducer available for 30 mm spindles.
See page 22 for details



Part No.	Description	Price
PPA-8536	Axial Live Tool System for Daewoo, Kia, Hyundai	\$470.00
PPR-8536	Radial Live Tool System for Daewoo, Kia, Hyundai	\$470.00
PPV-8536	Vertical Live Tool System for Daewoo, Kia, Hyundai	\$470.00
SRB-8500	Extra riser block, complete w/ hardware	\$80.00

DRILL HOLDER, ADJUSTABLE CENTER

- ◆ 5/8" shank diameter.
- ◆ Secure, center locking bolts.
- ◆ Accepts standard ECI 1/2" bushings.
- ◆ Thru hole in shank for deep drill insertion.
- ◆ Head adjusts for exact centering.
- ◆ **Bushing type holders allow clamping along any part of the drill.**

Once locked on center this tool provides a rigid platform for positive drilling. Also useful for small drill operations to achieve accurate centering.



Part No.	Description	Price
ADJ-2050	Adjustable center drill holder	\$65.00

TAP HOLDER, ADJUSTABLE CENTER

- ◆ 0.625 +0" / -0.0005" shank diameter.
- ◆ Black oxide finish and ground shank.
- ◆ Smooth slide floating inner sleeve.
- ◆ Spring load set for wide range of taps.
- ◆ Tap sizes 00-90 thru 1/2 -13.
- ◆ Adjustable head for exact centering.



A perfect tool for consistent, repeatable tapping. Free sliding inner sleeve protects the smallest tap while rigid enough for heavy coarse threads. Exact centering insures critical tap alignment.

Part No.	Description	Price
ATJ-2050	Non-releasing adjustable center tap holder	\$125.00

ER COLLET HOLDERS

- ◆ Adjustable inner stop screw to prevent push back & easy relocating.
- ◆ No need to buy individual collets for each drill size.
- ◆ Made from heat treated hardened & ground steel.
- ◆ Collets not included.



MINI NUT CHUCK



HEX NUT CHUCK

Part No.	Description	Shank	Price
AER-1140	ER 11 Hex Nut Collet holder	0.500"	\$75.00
ERC-1658	ER 16 Mini Nut Collet holder	0.625"	\$125.00
ERC-1634	ER 16 Mini Nut Collet holder	0.750"	\$125.00
WRE-1600	Wrench for mini nut chuck	—	\$28.00
ERN-1600	Replacement chuck nut	—	\$42.00

ER COLLET SETS

- ◆ 16 jaws provide parallel clamping & powerful gripping.
- ◆ 8 Deg taper for highest gripping power.
- ◆ Wide holding range of .0394 (1.0 mm) collapse.
- ◆ Accurate to within 0.0005
- ◆ Sold in sets only.

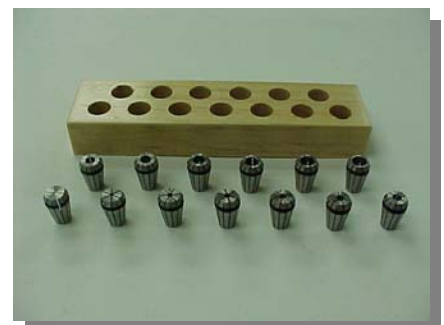

Part No.	Description	# in set	Price
AER-1113	1/32" thru 17/64" ER-11 Collet Set	13	\$190.00
AER-1610	1/32" thru 25/64" ER-16 Collet Set	10	\$180.00

DRILL HOLDER, ADJUSTABLE CENTER, CLAMP TYPE

Drill Holder firmly grips all tools within the capacity of the machines for which it is designed. Completely eliminates the need for cutting off tool shanks. Each pair of sliding jaws is independently mounted for adjustable movement.

Jaws may be quickly inverted to hold the smallest standard size drills.

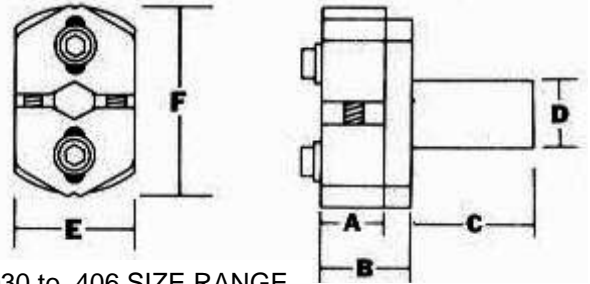

.030 to .406 SIZE RANGE

Part No.	Description	A	B	C	D	E	F	Price
NBD-3050	Adj Center, Clamp Type, Drill holder	.500	.750	2.375	.625	1.125	1.875	\$125.00

TAP HOLDER, ADJUSTABLE CENTER, CLAMP TYPE

Non-releasing type

Tap Holder requires no bushings, no collets, no extra jaws. Also important: need for cutting off tool shanks is completely eliminated. Tap Holder jaws firmly grip the tool along the full length of the jaws. This unit is the only tap holder with concentric self-alignment and adjustability for all taps within the capacity of the machine for which it is designed. Adaptable for use as a floating reamer holder

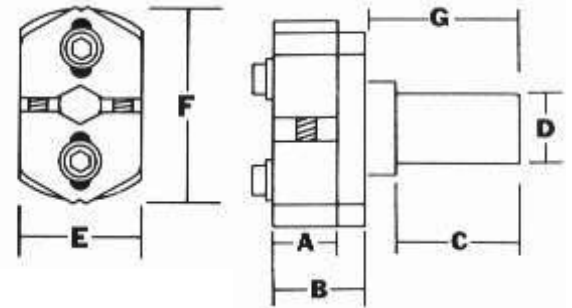

0-80 to .7/16-20 TAP RANGE

Part No.	Description	A	B	C	D	E	F	G	Price
NBT-3050	Adj Ctr, Clamp Type, Tap holder	.500	.750	1.187	.625	1.125	1.875	1.437	\$145.00

REAMER HOLDER, FLOATING

Designed for precision reaming, quick and accurate set-up. The Adjustable Floating Reamer Holders are self-centering, completely floating holders. The floating feature is simplicity itself. The master bushing with convex base engages a concave, loose-seating disc. After set-up, the setscrews, which center the bushing, are loosened slightly and the bushing is permitted to float. Eight sleeves are furnished for each standard size chucking reamer shank within capacity of the holder. Thus, the holder is complete in itself – no accessories needed. All these advantages add up to big savings in set-up and down time. Bushing sizes included: 7/64, 9/64, 11/64, 13/64, 15/64, 9/32, 5/16, 3/8"

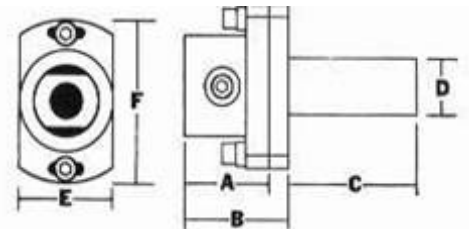

Part No.	Description	A	B	C	D	E	F	Price
ARJ-2050	Floating Reamer Holder	.875	1.125	1.125	.625	1.125	1.812	\$190.00

BAR TYPE TURNING OR THREADING TOOLS

- ◆ Right hand turning shown.
- ◆ Can be flipped over to use on either side of work.
- ◆ Also will do single point threading .
- ◆ Hex key wrench included.
- ◆ Rigid, well supported turning.
- ◆ Hardened alloy steel.
- ◆ Uses TPGH-321 insert for turning.



Part No.	Description	Insert size	Price
AST-4151	Bar Type Turning Tool 5/8" shank	TPGH-321	\$35.00
AST-4161	Bar Type Turning Tool 3/4" shank	TPGH-321	\$35.00

AXIAL APPROACH KNURLING TOOL

- ◆ The perfect tool when space is an issue.
- ◆ Knurl from either side to save travel time.
- ◆ Quick change c-clip release.
- ◆ Hardened Tool steel.
Knurl not included.



Part No.	Description	Knurl Type	Knurl I.D.	Price
AKA-6250	5/8" Shank Axial Knurling Holder	GK or KN	0.250	\$30.00
AKA-7500	3/4" Shank Axial Knurling Holder	GK or KN	0.250	\$35.00
AKA-7501	3/4" Shank Super Duty Knurling Holder	PH	0.500	\$38.50

SIDE KNURLING TOOL

- ◆ A very sturdy & rigid tool
- ◆ Ideal for bump or straight turn knurling
- ◆ Quick change c-clip release.
- ◆ Uses **GK series** knurls.
- ◆ Can be used on either side of the work piece.
- ◆ Heat treated tool steel.
- ◆ Hardened and ground pin.
- ◆ For 3/8" square turning tool holders & up.
Knurl not included



Part No.	Description	Knurl I.D	Price
AKR-0375	Side Knurling Holder	.250	\$56.25

REVOLVING STOPS

- ◆ Smooth rotating head and positive stopping action insures precise feed outs with out the need for facing.
- ◆ Can withstand severe conditions and still outperform other types on the market.
- ◆ Available in 5/8" or 3/4" diameter shank.



Part No.	Description	Price
ARS-0050	5/8" revolving bar stop	\$35.00
ARS-0060	3/4" revolving bar stop	\$45.00

THREADING DIE HOLDER

- ◆ Allows threading of long small diameter threads.
- ◆ Oil wash cross holes for proper lubrication.
- ◆ 5/16" shank
- ◆ Made from strong aircraft aluminum.
- ◆ Use with sliding tap holder, (not included)
- ◆ Uses 13/16" button dies.



Small diameter threads are difficult to impossible when single pointing. This tool will provide a final solution for this type of application, while maintaining the versatility to thread up to 5/16"-18. Initially developed for Swiss cam automatics.

Part No.	Description	Price
BDH-1316	Button Die Holder	\$35.00

Z-ZERO TOOL SETTING FIXTURE

- ◆ Lines up all tools on a single plane.
- ◆ Set one tool "zero " point on the part and enter the same offset for all, without doing each individually.
- ◆ Simply insert and lock into a .750 collet.
- ◆ Tool plate is ground to insure accurate length setting.
- ◆ 3/4" shaft size, 12" long setting area.

Part No.	Description	Price
ASA-7500	Tool setting fixture	\$75.00



ADAPTER SLEEVES

- ◆ Standard and Metric sizes..
 - ◆ 0.0002" concentricity .
- ◆ By purchasing all 3/4" multi-station tool blocks, both 3/4" & 5/8" shank tooling can be used.



Part No.	Description	Price
ABR-3458	3/4" to 5/8" adapter sleeve	\$25.00
ABR-3412	3/4" to 1/2" adapter sleeve	\$25.00
ABR-3438	3/4" to 3/8" adapter sleeve	\$25.00
ABR-5812	5/8" to 1/2" adapter sleeve	\$25.00
ABR-5838	5/8" to 5/8" adapter sleeve	\$25.00
ABR-2010	20 mm to 10 mm adapter sleeve	\$25.00
ABR-2012	20 mm to 12 mm adapter sleeve	\$25.00
ABR-2016	20 mm to 16 mm adapter sleeve	\$25.00

PRECISION SLEEVE ADAPTERS

- ◆ Precision ground
- ◆ Gentle but secure clamping on spindle
- ◆ Eliminates the need to purchase additional holders.



Part No.	Description	Price
ABR-3630	36 mm to 30 mm Adapter Bushing	\$60.00
ABR-3610	36 mm to 1.00" Adapter Bushing	\$60.00
ABR-3625	36 mm to 25 mm Adapter Bushing	\$60.00

RISERS ADAPTERS

UP TO FIVE TIMES MORE TOOLS ON YOUR SETUP

Increase your productivity, efficiency & profit
Decrease tool to tool time, overall job time, & labor cost

Every inch of your X travel is precious space, especially when doing intricate parts with many operations. When working with a 1 1/2"+ spindle bore machine, one needs not only rigidity, but efficient use of table space. Large OEM holders address the rigidity but use a lot of area, as they are mounted directly to the machine table and must achieve a stretch of up to 85mm (3.346") to the spindle center.

Our riser adapters used with the 3/4" & 1/2" center height tooling, provides: 1) More than doubling the quantity of tools, 2) a rigid work platform, 3) And a much broader selection of tooling options. Easy bolt on to all 85, 55, 38 or 35 mm spindle center height machines.

Every Riser comes with all hardware for instant bolt on

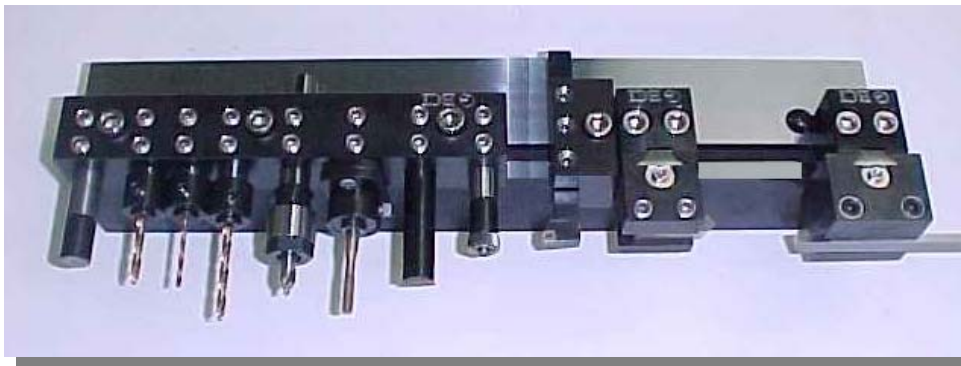

85 MM SOLID RISERS

FOR DAEWOO, KIA, OR HYUNDAI

Available in two lengths:

- 17" for full travel or 12" when using a sub-spindle.
- Easy one time bolt down to machine table.
- Aligned into table slots with dowel pins for exact perpendicularity.
- Hardened and ground alloy steel. Black oxide finish.
- Five hold down bolts with tee nuts.
- For all 85 mm **Daewoo, Kia & Hyundai** machines.
- For use with 1/2" or 3/4" center height tool holders.



- **DAEWOO** **150G / 160 / 220G**
- **KIA** **KIT30**
- **HYUNDAI** **HIT-400G**

Part No.	Description	Price
ROP-8512	12" long, one piece solid riser, for 3/4" ctr tooling	\$700.00
ROP-8517	17" long, one piece solid riser, for 3/4" ctr tooling	\$750.00
ASP-8517	Ground plate, converts ROP-8517 to 1/2" ctr tooling	\$150.00

85MM QUICK CHANGE RISERS FOR DAEWOO, KIA OR HYUNDAI

A modular design in which the base unit is precisely located with table slot locators and bolted down to the machine table. The quick change top plate is then placed on top, and located against 5 hardened & ground dowel pins and bolted to the base. Proceed with normal job set-up and production. When the job is complete the quick change top plate is removed and stored with the tooling intact. The tool's off sets are saved with the program. To set the same job up the next time, the previously set up tooling and top plate are re-bolted, a collet change, and push start cycle. Perhaps 10 minutes max. Set up time cut to almost nothing, the unit pay for itself in very quickly. This system uses 3/4" center height tooling. 1/2" center height top plate is special order, depending on your preference or application. Direct bolt on, no modifications needed for the following models:

DAEWOO, KIA, HYUNDAI.



- DAEWOO 150G / 160 / 220G
- KIA KIT30
- HYUNDAI HIT-400G

Part No.	Description	Price
RTP-8517	85mm X 17" Quick change top plate	\$500.00
RBP-8517	85mm X 17" Quick change base	\$750.00
RQC-8517	Quick change set-up system (both above)	\$1250.00

GANG TOOL ADAPTER FOR THE WASINO G07



EASY BOLT ON INSTALLATION, HARDWARE INCLUDED.

UNLOCK THE FULL POTENTIAL OF YOUR PRECISION LATHE CNC CONTROL .

MAKE ONE PART OR THOUSANDS WITHOUT AN OPERATOR CHANGING OR INDEXING TOOLS.

UNLIMITED TOOL CONFIGURATIONS.

USES 3/4" CENTER HEIGHT TOOL HOLDERS

FULLY SURFACE GROUND STEEL CONSTRUCTION.

ADJUSTABLE HEAD DRILL AND TAP HOLDER RECOMMENDED FOR QUICK AND EXACT CENTERING.

MANY OTHER ECI TOOL HOLDERS TO CHOOSE FROM TURNING, FORMING, THREADING, TAPPING, BORING, CUT-OFF, TREPAN, FACING, RECESSING, KNURLING, CROSS DRILLING, SLOTTING, MILLING, AND MORE.

ALL COMPONENTS MADE IN THE USA.

Part No.	Description	Price
WAS-5510	10" LONG G07 GANG TOOL ADAPTER	\$300.00

SPARE PARTS

PIN-2495	PIN, LOCATING, PRECISION, POSI POST	\$3.00
TEE-3816	NUT, SQUARE, TEE, 3/8"-16	\$1.75
SCR-0800	SCREW, POSI-LOCK ADJ	\$7.50
BLT-0175	BOLT, TOOL POST, PPS-0175	\$3.00
BLT-0150	BOLT, TOOL POST, PPS-0150	\$3.00
DOV-1500	DOVETAIL, POSI-LOCK, UNIVERSAL	\$20.00
SET-3824	SET SCREW, HALF DOG, 3/8"-24 X 1/2"	\$1.00

Gang Tool Machining Advantages

Gang tooled lathes provide a reliable, fast method of tooling setup, yet very few operators extract the best from this style of machine and tooling.

We hope these pages assist you in optimizing your next set-ups.

More Tools on the table

When we purchase machine tools, we want the best range of features, at the best price, so we generally buy more than we need, just in case that big job comes in, but we have to make sacrifices for that flexibility.

With gang tool lathes that generally means that the larger standard holders are great for that big job, (because the machine manufacturer has to provide for the maximum load that you can put on the tools.)

But for the small work, we are always looking for room to load that last tool, This is where you can benefit the most.

If you can stack the tools closer together for parts under 1" you can :

- Get more tools on the plate
- Change over setups quickly
- Be more flexible on the small jobs

Most turning tools are square shank, but you can get the same results by using boring bars for turning,

There are other benefits also, you can cut inside the part and outside with 1 tool, plus a boring bar takes up a lot less room on the tool plate.

You can stack 2 bars back to back for outside turning and threading.

Consider that most jobs 1" & under, on a gang tool lathe run up to 3" long, and you can overhang a boring bar 4 times its diameter.

A 3/4" boring bar is not over extended for that application. ($3/4" \times 4 = 3"$)

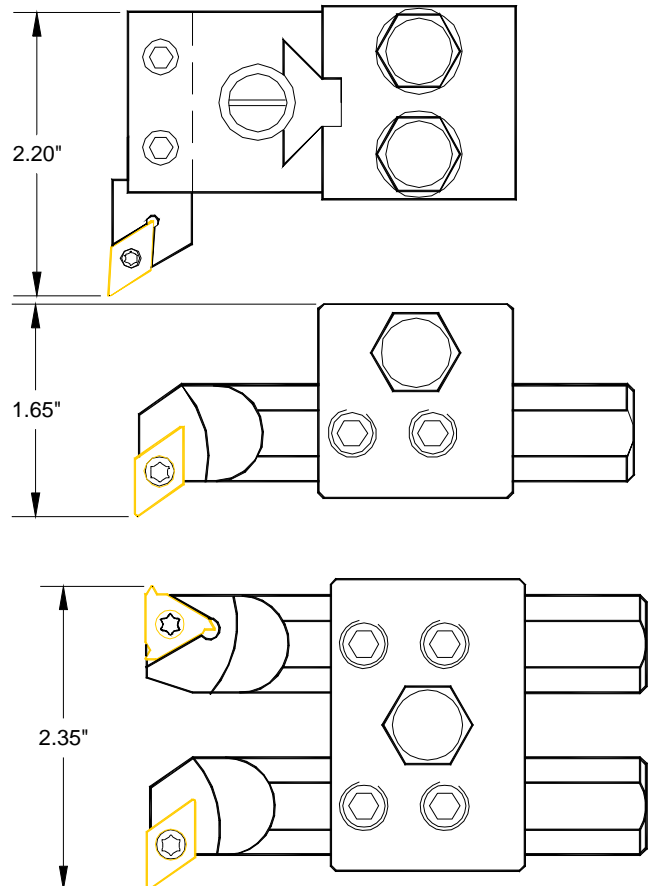

Multi hole holders

When drilling you can use a multi tool holder and stack your drills close together.

Combining groups of tools simplifies setup greatly.

An NC spot drill (90° point), a drill, and a tap holder provide an ideal 3 position group for many jobs.

Simply swapping a drill and tap and a quick change over is achieved.

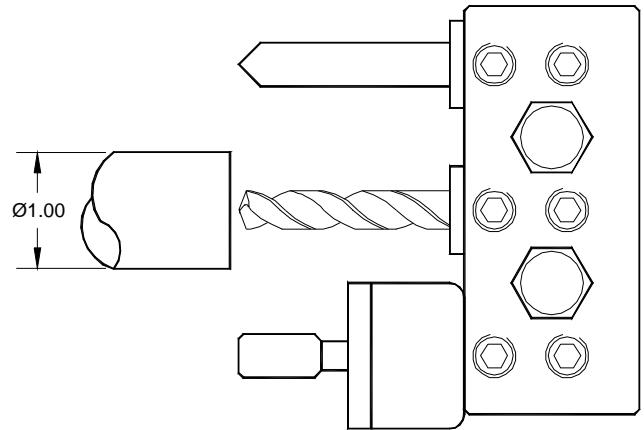

When choosing a threading tool, a grooving style holder (Top notch style) can provide a quick change from grooving to threading inserts.

Combining turning & grooving bars in a 3 position holder can allow fast rough and finish of the front & back of a part in a small table space.

The setup shown requires a spindle direction change, this can be solved by using a left hand boring bar running upside down.

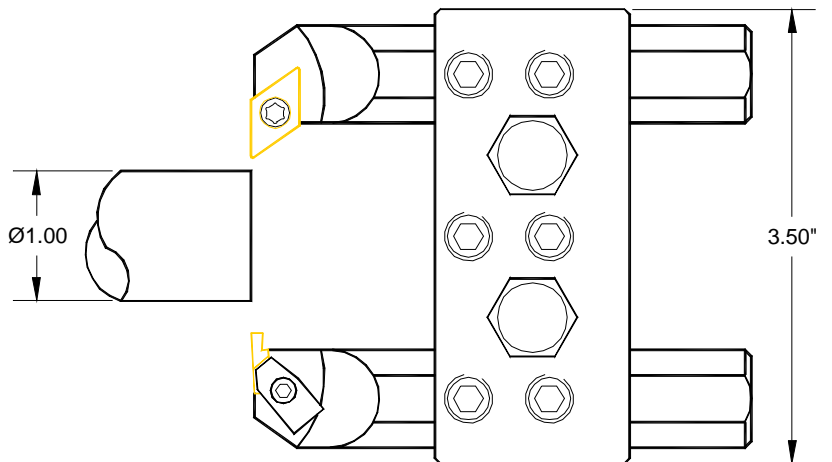

A two position holder is ideal for a simple center drill & drill. The picture shown uses 2 reducer bushings. ER11 or ER16 collet holders offer great flexibility for drill holding.

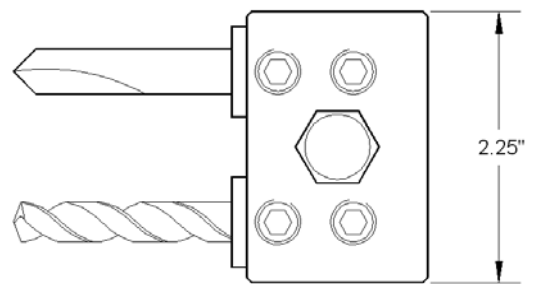

Cutoff Tools

Cutoff tools for large diameter holders require a deep throat to accommodate 1" diameters, if your part is less than 0.5" diameter a thin grooving insert works well, (Nikcole manufacture a great range of inserts for grooving and turning) Thin Bit also has a wide range of inserts.

This allows a 5/8" or 3/4" bar for cutoff, saving almost an inch of table space. The boring bar cutoff can also be used in a multi-position holder,

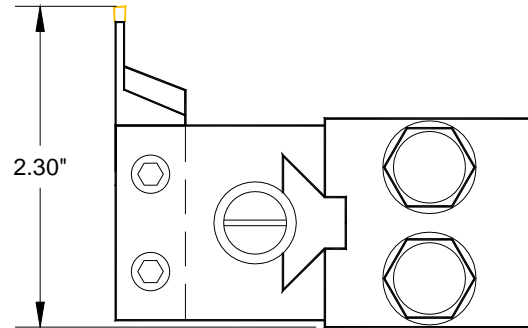
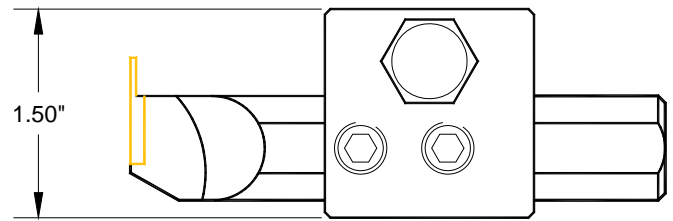

Longer Parts

Sometimes a longer part requires machining using 2 holders, this can be achieved easily.

This example shows the ability to turn a longer part, or perhaps a tough material that required more rigid tooling than a boring bar.

This setup lends itself to form tooling to decrease cycle times even further.

Either tool can be upside down so that a change of spindle direction is not required.

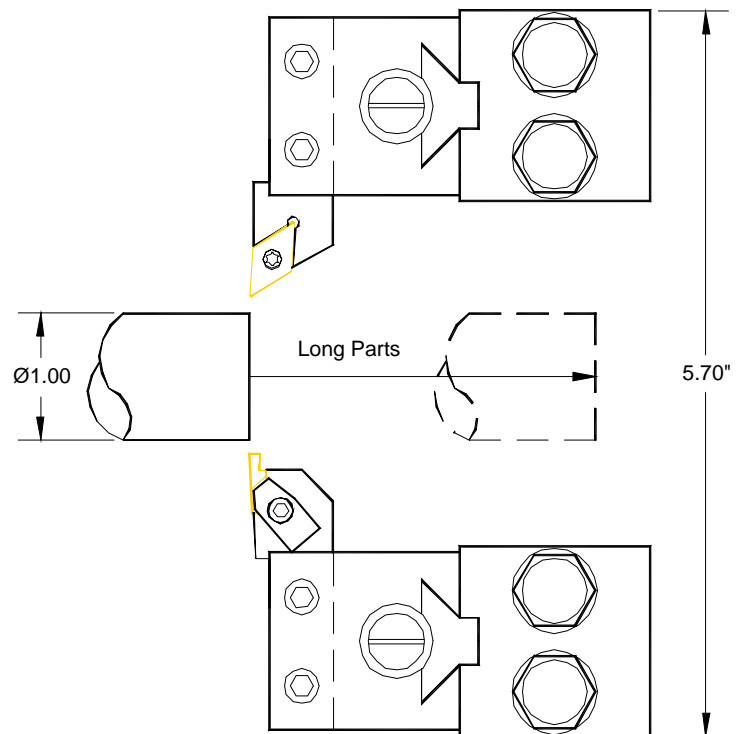

4, 6, & 8 Position Holders

If your parts require frequent repeat setups a large capacity holder can save time and money.

Load your tools once in the holder, setup your offsets and at the end remove the tool holder with the tools still mounted. The next time this part is required, simply load the holder onto the plate and locate it against a known stop,

Load the offsets from the last time it was setup. And you are ready to run.

(On most CNC controls you can download the offsets to a PC or load the offset data in a program that is after the M30 end of program) simply run the stored offset program to load the tool data.

This method of setup may seem expensive (saving tools on the shelf) but let us evaluate these numbers:

1 eight position holder = \$320.00
 6 tools at \$150.00 each = \$900.00
 Total tool cost = \$1220.00

If your setup labor rate is \$80.00 hour and a new setup takes 2.5 hours typical setup cost is \$200.00

A new setup with would cost \$200.00

The next setup should take 10 minutes to load the new tool bar and run offset section of program.

Saving you \$190.00 per setup. Pay back is achieved at 6.4 setups. The more complex the setup the faster the payback time. If a 6 position holder is used payback is even faster (lower holder cost).

This example can be used as a basis for your payback time.

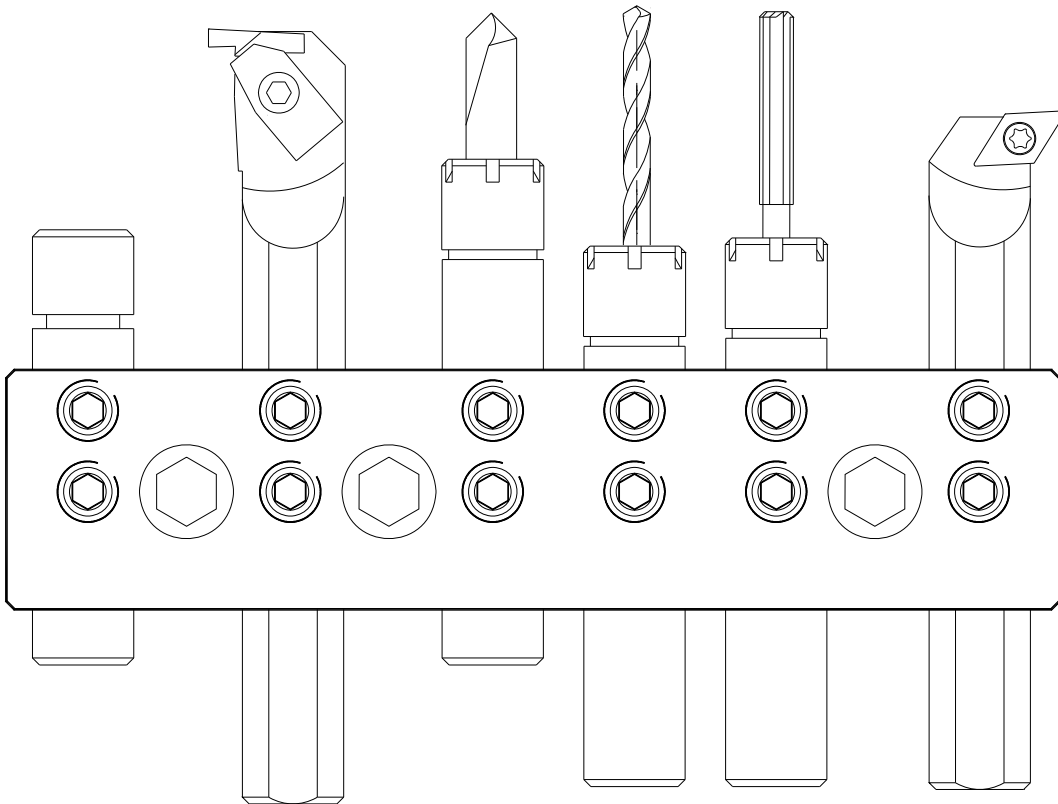

**Engineered Concepts Inc.
Your Gang Tool resource**

To our valued customers,

It is our pleasure at ECI to present this catalog to you for your tooling needs. We strive to provide solutions to manufacturing production, by finding new ideas to tooling and presenting them to you.

Our target of gang tooled lathes is based on the knowledge that our industry is making decisions on machine tools that is changing the face of our industry, smaller more cost effective machines, with smaller footprints, are now very popular, and our tooling is designed to fulfill the needs of reasonable cost for these smaller machines.

Sincerely,

Joseph Davis, Pres.

Engineered Concepts Inc.

ENGINEERED CONCEPTS STANDARD SALES POLICY

Conditions of sale:

All sales are made in accordance with our standard conditions of sale, current at the time orders are accepted. Specifications and prices subject to change without notice. Returns: A 20% restocking charge will be assessed for all returns to stock. No cash refunds. Your account will be credited for all returns. Defective material will be repaired or replaced only. All returns must be first approved by ECI. Returns on special order items will not be accepted. Un-defective **USED** items will not be accepted. Purchaser assumes all Risks Of Liability & Damage due to improper use of products. .
(NO EXCEPTIONS)

Terms of payment:

All first time orders are C.O.D. Visa or Mastercard. Subsequent order payment terms are NET 30 days upon credit application approval. We reserve the right to hold shipments or to ship on a C.O.D. basis, on any order received by a customer whose account is delinquent. A service charge of 1½% per month will be assessed on all passed due accounts. A \$90.00 service charge will be assessed for all returned checks.

Order processing:

Orders generally take one to five days to process for shipment.

Due to varying daily volume, orders with extensive document requirements, short time restraints, incomplete information, etc., ECI can not guarantee same day delivery. ECI shall not be responsible for, computer or electronic interruptions, mechanical or electrical breakdowns, severe weather conditions, or any other forces beyond the reasonable control of ECI, non-scheduled carriers, back-ordered or out of stock items, replacement orders, new accounts (first order), and orders requiring credit review.

Delivery Terms:

F.O.B. Franklinville N.J. All shipments are made by regular UPS, or truck. All UPS shipments are insured. Specify shipment method if other than standard UPS ground. Next day Red / 2nd day Blue / 3 day select shipments are at the customers expense under all circumstances. Freight expenses on returned items are the customers responsibility.

Product warranty:

ECI will repair or replace any of its products which, in its judgment, are found to be defective in material or workmanship. All claims must be made in writing within 15 days after receipt of product. (NO EXCEPTIONS) No claims for labor or damages will be allowed. In no event shall ECI be liable for consequential damages or special damages of any kind.

Special tool quotations:

Orders for special tools must be confirmed in writing before manufacturing can begin, along with payment of 50% of the quoted price, with the remaining 50% to be paid on delivery of the special item. Special items and non-stock standard items cannot be cancelled or returned for exchange or credit.

Claims:

Claims for loss in transit must be made against the transportation company. The foregoing shall constitute the sole and exclusive remedies of the customer and are in lieu of all other warranties, expressed, implied or statutory, including but not limited to any implied warranty of merchantability or fitness. Warning: The responsibility for correct fit and proper use, lie with the user. The information in the catalog is provided for general reference. ECI will not participate in customer machining engineering, turn key set ups, or general job engineering of any kind. (NO EXCEPTIONS)

Conditions, terms, and prices are subject to change without notice.

Any typographical or other error in this catalog is subject to correction.

